

Build This

ELECTRONIC COMPUTER

At the quick spin of the dial it adds, subtracts, multiplies or divides.

By MORRIS GROSSMAN

MARVEL of the space age, the electronic computer in a fraction of a second can solve problems which would take a team of mathematicians years to work out. Unfortunately, the giants are much too expensive and sophisticated for solving down-to-earth problems involving ordinary arithmetic.

Using many of the techniques found in its bigger brothers, our computer can add, subtract, multiply and divide. And it does so in decimal numbers with direct readout to six figures (999999). Operation couldn't be easier. Push a button to clear, turn a switch to the column of figures you want to add, then dial in the numbers. You see the answer instantly and directly on glowing neon lamps.

The computer is a complicated and expensive project. However, you'll be paid back many times over by the use and experience you'll get from it.

The Big Picture

The computer consists of four *functional* parts (see Fig. 14). They are: 1)

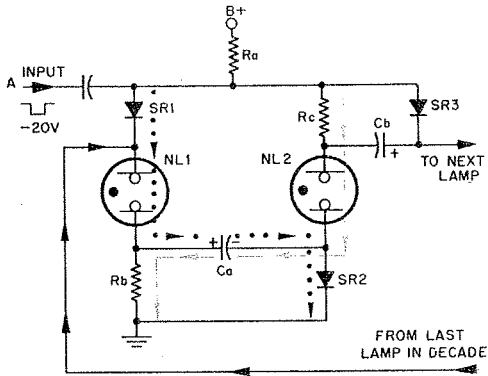

Fig. 1—Simplified counter: NL1 is on, NL2 off. Input pulse turns NL1 off, NL2 on. Next input pulse turns NL2 off, next lamp on. NL1 stays off.

Six decimal decade counters which count pulses and provide a readout on neon lamps. 2) Six buffer/inverter amplifiers which carry pulses from one decade counter to the next higher decade counter. 3) A regulated power supply. 4) A telephone-dial input device. A reset switch sets all the decade counters to zero. A six-position rotary switch selects which decade counter the telephone dial's output is fed to.

How it Adds

You may not realize it but when you used your fingers to help you with addition and subtraction, you operated the first computer.

Our computer's operation is based on the same principle. Let us say you want to add 3 and 5. You would first count 1, 2, 3 on your fingers by bending them. Then you would continue: 4, 5, 6, 7, 8. In a similar

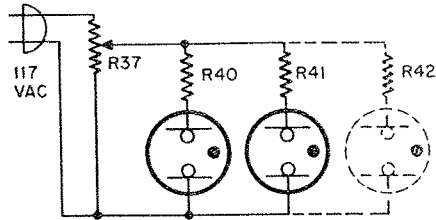

Fig. 2—Neon-lamp aging circuit. Adjust the potentiometer until the voltage drop across the resistors averages out to about 30 V.

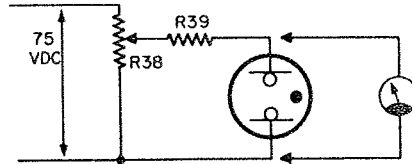

Fig. 3—Lamp classifier. Raise voltage on each lamp and measure when it lights. Lower voltage and measure when lamp goes off.

manner, dialing a 3 into our computer, puts three counts, or pulses, into a decade counter, and the 3 lamp lights. Dialing the number 5, introduces five more pulses, and the computer continues on from lamp 3 to lamp 8, which is the answer.

As you may recall from finger-counting, if the sum of two numbers is greater than 10, a problem arises. You had to remember when you passed 10 after you continued counting from your second hand back to your first hand. Thus, if the numbers to be added were 9 and 3, you would have first counted to the number 9 on both hands. Then you would have continued: 10, then 1 and 2 on the first hand again.

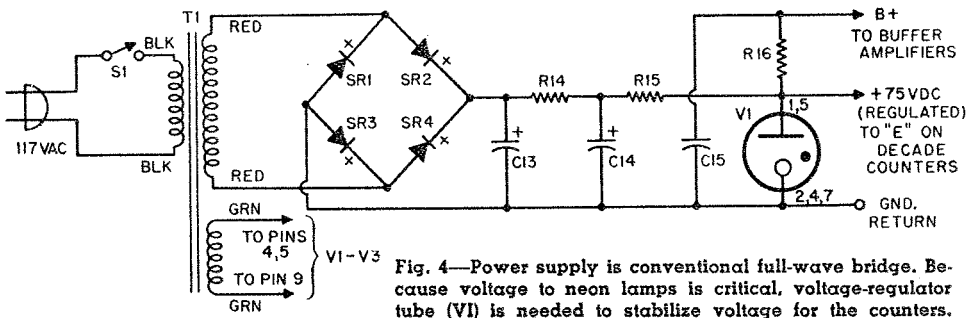

Fig. 4—Power supply is conventional full-wave bridge. Because voltage to neon lamps is critical, voltage-regulator tube (V1) is needed to stabilize voltage for the counters.

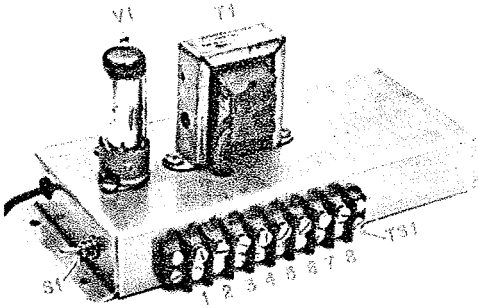

Fig. 5—Power supply is built on 3 x 6½ x 1¼-in. aluminum chassis. Barrier-type terminal strip simplifies making many connections to power supply.

When you passed 10 you had to make 10 plus 2, or 12, your answer. The computer does the same thing. Take a look at Fig. 14. With S2 set to 1, you dial a 9. The dial generates nine pulses which are fed to and registered in the first, or units, decade counter. The decade counter counts to nine, and the 9 lamp lights up and stays lit. Dial a 3 and

the counting continues from the 9 lamp. However, when the first pulse of the number 3 goes into the units decade counter, the zero lamp comes back on and a pulse is automatically sent to the second, or tens, decade counter lighting its 1 lamp.

Then the units decade counter continues to count the two additional pulses and registers a 2. The computer now indicates 12. In other words, the tens decade counter, by registering

Power Supply Wire Destinations	
Wire	Destinations
A	J, buffer amplifiers board
B	K, buffer amplifiers board
C	C, 1 decade counter board
D	C, 10 decade counter board
E	C, 100 decade counter board
F	C, 1,000 decade counter board
G	C, 10,000 decade counter board
H	C, 100,000 decade counter board
I	E, 1 decade counter board
J	E, 10 decade counter board
K	E, 100 decade counter board
L	E, 1,000 decade counter board
M	E, 10,000 decade counter board
N	E, 100,000 decade counter board
O	L, buffer amplifiers board
P	I, buffer amplifiers board

Fig. 6—Underside of power supply. Layout is wide-open, making wiring easy. Table in right column above tells where leads marked A through P are connected. Don't put more leads on lugs than are shown or there may be trouble. Drill oversize holes in chassis and deburr them for leads coming out to terminal strip.

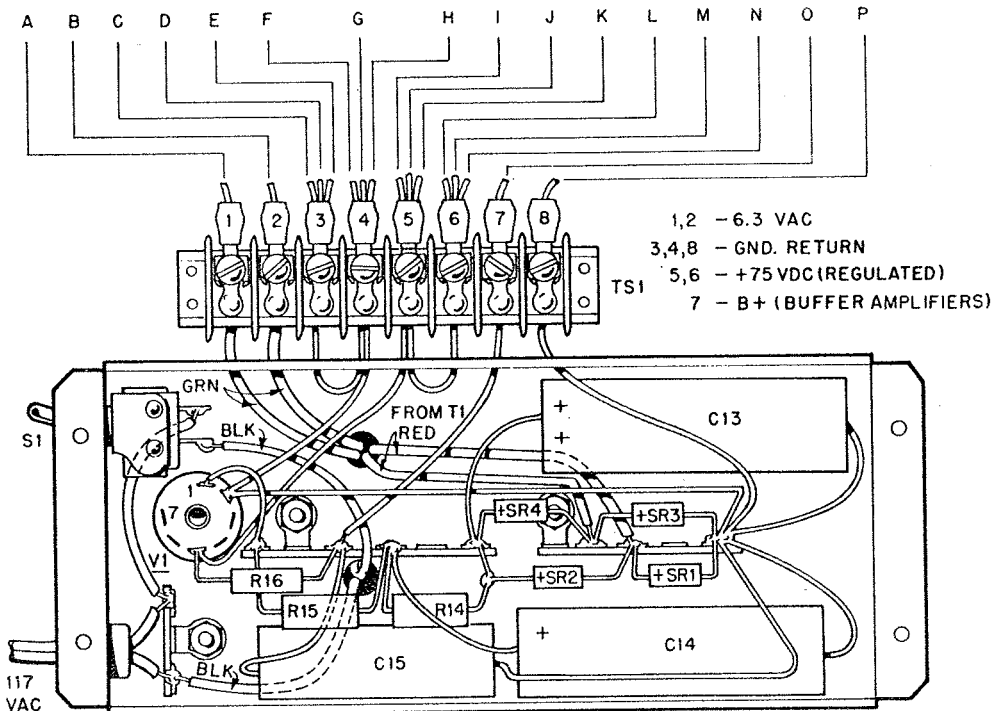

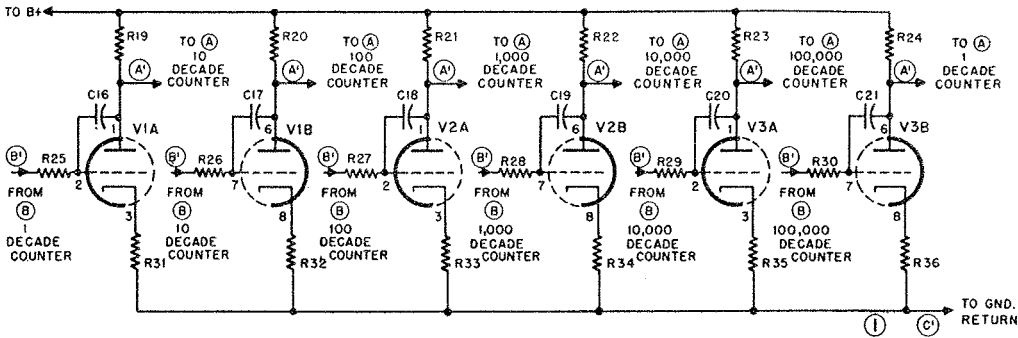
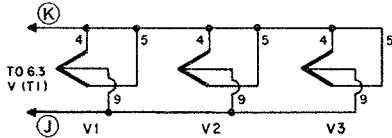

Fig. 7—Buffer/inverter amplifiers. Each amplifier's input (B') receives signal from zero lamp (NL1) of each decade counter (B, Fig. 11), inverts it and feeds it to input (A, Fig. 11) of next higher decade. To perform end-around-carry (subtraction), V3B's output goes back to units decade.



ELECTRONIC COMPUTER

a 1, every time the first decade counter's zero lamp comes on, acts as a memory to tell you that the sum is 10 or larger. This operation is called carrying.

When each decade counter goes past 9, it sends a carry pulse to the next higher decade counter. If say 000999 is indicated by the lights, and an additional 1 is dialed into the units decade counter, the units decade counter would switch its 9 lamp *off* and its zero lamp *on*, and feed a pulse to the tens decade counter. The 9 lamp on the tens dec-

ade counter would go off, zero lamp would come on, and a pulse would be sent to the hundreds decade counter. The hundreds decade counter would do the same, but since the thousands decade counter is registering a zero it would merely indicate 1. The computer would now register 001000 which is the sum of 000999 plus 1. We'll get to subtraction, multiplication and division later.

How the Decade Counters Count

The most important parts of the computer are the six decade counters. (Fig. 10, 11 and 12.) Their circuit is known as a ten-count ring counter because as pulses are fed into it, one neon lamp after the other lights until

Fig. 8—Underside of buffer/inverter amplifiers board. Leads at top go to input A on each decade counter. Leads at bottom go to output B on each decade counter. Use heavy wire to tie I, J, K, L to power supply.

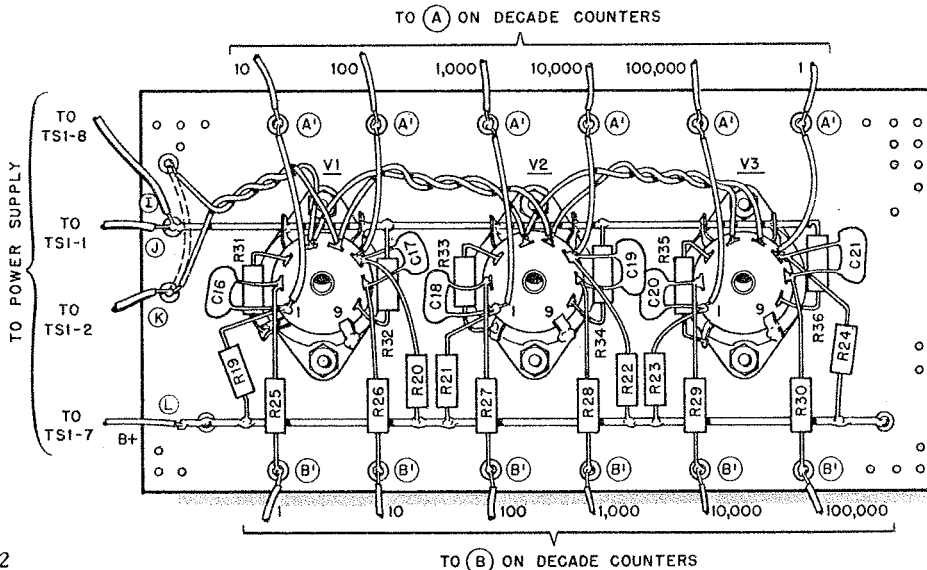

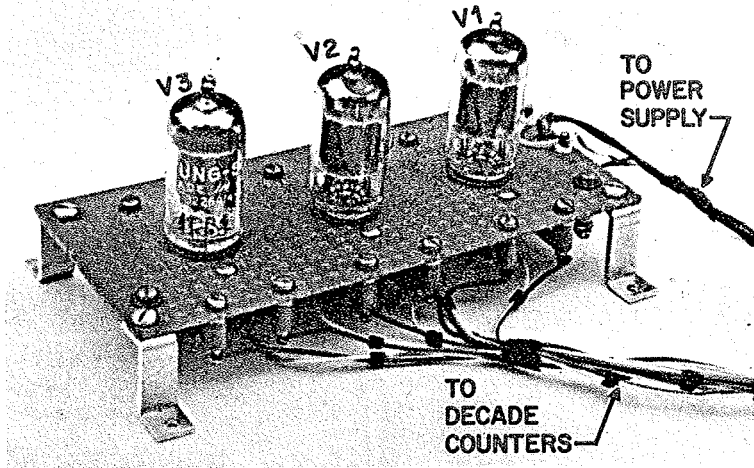

Fig. 9—Photo of buffer/inverter amplifiers. Our model was built on perforated board. Small brackets are used at corners to keep above cabinet and for mounting. However, you could build circuit on same size open-end chassis as power supply. The posts are used to connect leads to decade counters but ordinary terminal strips will do the job just as well.

the last, or ninth, lamp is lit. On the tenth pulse, it starts all over again from zero. If the lamps were arranged in a ring, they would appear to run around in a circle as pulses are fed to them.

To see how they work, take a look at Fig. 1, a simplified circuit showing only two neon lamps. Consider neon lamp NL1 *on* and neon lamp NL2 *off*. In this condition Ca is charged from B+ via the dotted path through diode SR1, NL1 and SR2 to ground. When a pulse of approximately -20 V is applied to the input, the voltage on NL1 drops below its extinguishing voltage, and NL1 goes off.

The charge on capacitor Ca now acts along the dashed path. Ca's voltage, therefore, is

now in series with NL2 and the main B+ supply. This causes NL2 to light as soon as the negative pulse disappears. Capacitor Cb is then charged with the polarity shown. Cb then turns on the next lamp (not shown) in a similar fashion, when the next pulse is applied, and so on along the line.

The value of Ra is chosen so when one lamp is lit, the voltage on the input buss will be below the firing voltage of the other neon lamps in the decade. This keeps the other lamps off. When another input pulse arrives and extinguishes the lamp that happens to be lit, only the next higher lamp (to the right) goes on. The reason only the succeeding lamp goes on is that it gets an extra voltage boost

Fig. 10—Decade-counter circuit board (build six). A 3 x 7-in. piece of perforated board is large enough but you could make it bigger to simplify wiring. Use spaghetti on leads wherever they cross.

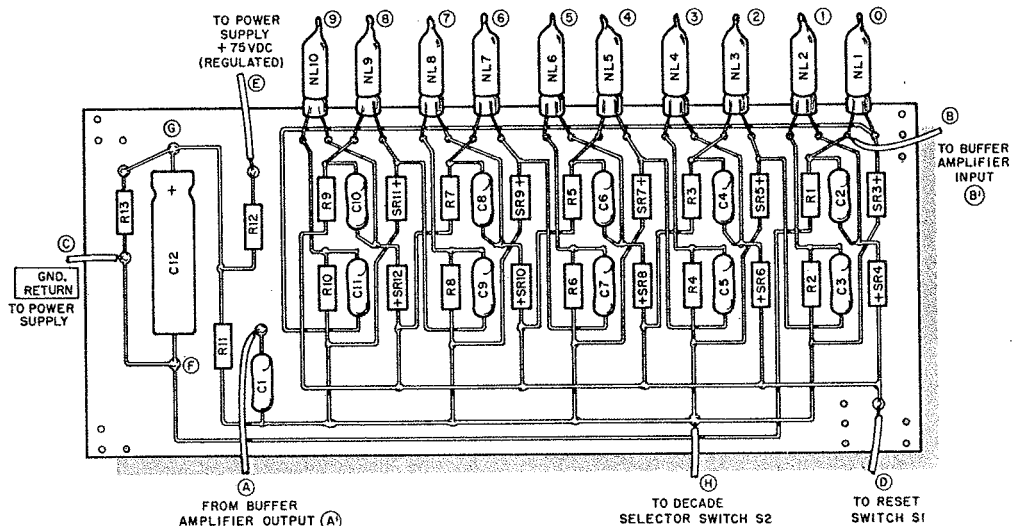

from its adjacent capacitor, such as Cb.

Construction

Aging the Neon Lamps. The secret of the computer's stability and accuracy lies in the aging and then selecting matching sets of neon lamps. Very little equipment, but a good measure of patience, is required. Since at least 60 lamps are needed, it is wise to start with a quantity of 100 since some may not work properly.

Figure 2 is a schematic of the aging circuit. Using a 10,000-ohm 4-watt (wire wound) potentiometer (R37), adjust the voltage to all the lamps so that there's a 30-V (AC) drop across the 100,000-ohm ½-watt resistors (R40, R41, R42, etc.) in series with each lamp. Leave the lamps on for a period of at least 24 hours. Forty-eight hours is better if you're not in a hurry.

You will find some of the lamps will cause a higher or lower drop across the resistor. Choose a setting of R37 to average out the voltages. After this initial period, reduce the voltage across the resistors to 10 V and leave power on for an additional 24 hours. Since a 100,000-ohm ½-watt resistor is required for each lamp, the 100 lamps can be aged in batches of 25 to keep the cost down.

The Power Supply

The power supply is a conventional full-wave circuit which uses a voltage-regulator (VR) tube (Figs. 4, 5 and 6). Such a tube is required as the neon-lamp decade counters' operation is very dependent on correct voltage level. They will not operate properly if the voltage is too high or low. While the lamps are aging, build the power supply as you'll need it for lamp selection and for the final adjustment and checkout of the decade counters.

Build the supply on a 3 x 6½ x 1¼-in. aluminum chassis. Except for the normal precaution of observing electrolytic polarity, the power supply should present no problems. To provide isolation, you must use several power and ground lugs on TS1 for the decade counters and buffer amplifiers. Hence, the reason for so many connections to terminal strip TS1 in Fig. 6. It is a good idea to turn on the power supply, and let it burn in for a period of 24 hours, to stabilize the VR tube.

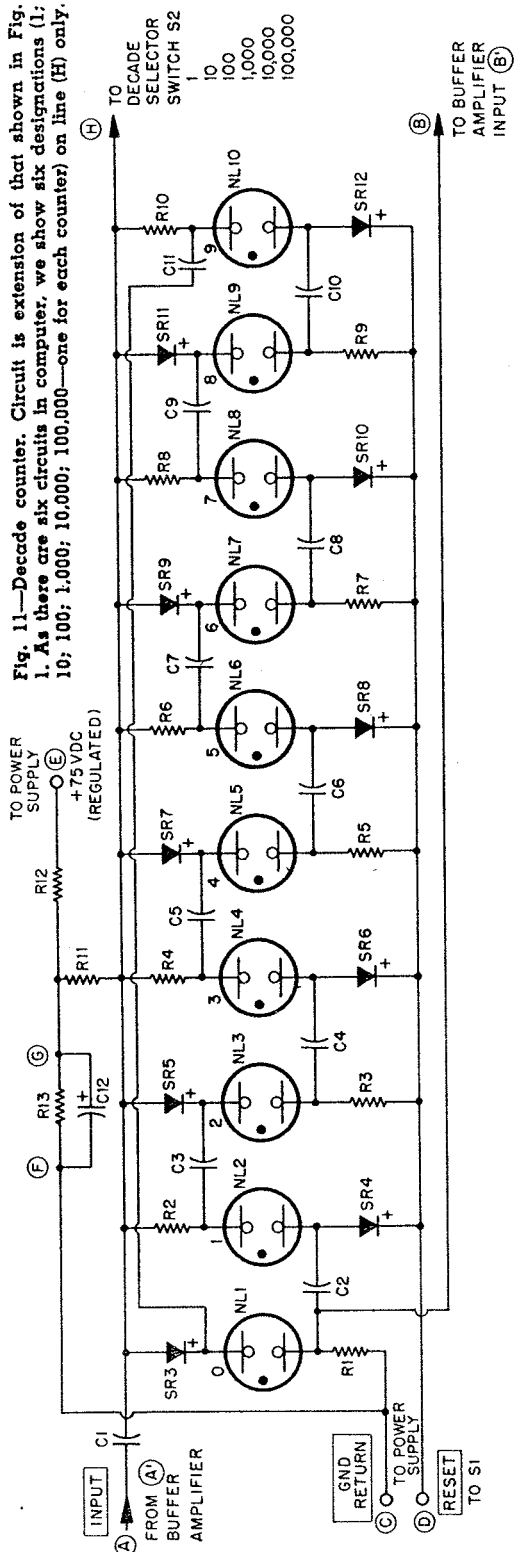

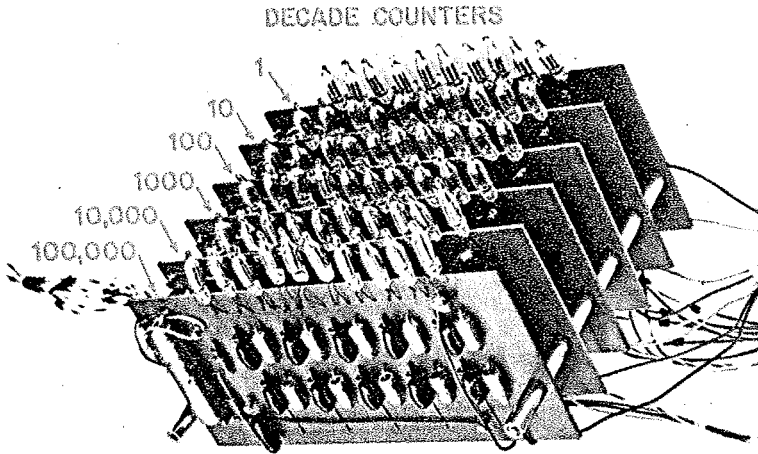

Fig. 12—Decade counters. Author used printed-circuit boards instead of perforated board and flea clips. After all neon lamps are installed, join boards with ½-in.-long spacers at ends. Entire assembly is held to side of cabinet with spacers which appear at bottom of the photo.

Lamp Selection

After all lamps have been aged, start selection. Using the circuit in Fig. 3, and the 75 VDC output of the power supply, turn potentiometer R38 slowly until the lamp fires. Measure the voltage across the lamp. (The firing voltage will range from about 63 V to 75 V.) Reduce the voltage until the lamp goes out. Measure the lamp voltage again. Write these voltages on a piece of masking

tape and stick it on the lamp. Repeat this for every lamp and then arrange them in groups according to firing voltage. Within each firing-voltage group sort the lamps according to extinguishing voltage.

When selecting the lamps for the decade counters, start with the lower-firing-voltage group, and select batches of ten lamps whose firing voltages are within 3 V of each other. Also, choose those that have the lowest ex-

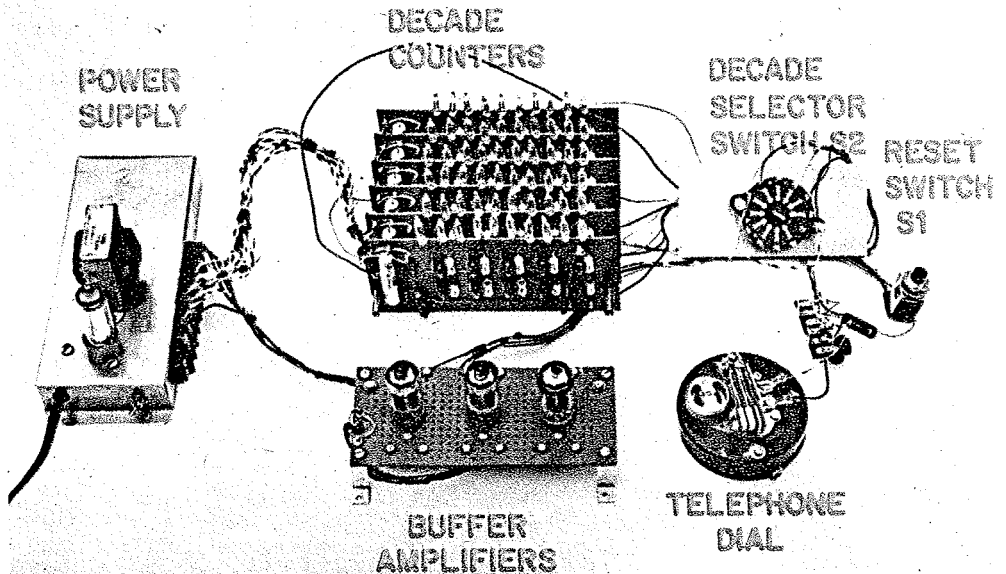

Fig. 13—Individual computer parts. Use long wires to hook up parts so they can be connected before they are installed in cabinet. Once put in cabinet, it will be almost impossible to connect the wires. Mount decade-selector switch S2, reset switch S1 and the telephone dial on bottom of cabinet's front panel.

ELECTRONIC COMPUTER

tinguishing voltage (if you have enough to choose from within each group). We found that the lower-firing-voltage lamps tend to be more stable. Another tip: leave a few extra lamps in each of the voltage groups for final selection during later circuit adjustment.

The Buffer/Inverter Amplifiers

Figure 7 is the schematic of the buffer/inverter amplifiers. Each amplifier's input (B¹) is connected to the load resistor (R₁, Fig. 11) of the zero lamp of each decade counter. The output of each amplifier goes to the input of the next higher decade counter. To perform the end-around-carry for subtraction (more about subtraction later), the output of the hundred-thousands decade-counter amplifier (V3B) is fed back into the units decade counter. This has no effect on normal addition.

PARTS LIST

Capacitors: 100 V silvered mica unless otherwise indicated

C1, C24—.01 μ f
 C12—12 μ f, 150 V electrolytic
 C13, C14—40 μ f, 150 V electrolytic
 C15—1 μ f, 200 V tubular (not electrolytic)
 C16 through C21—150 μ f μ f
 C22—.05 μ f C23—.1 μ f
 NL1 through NL10—NE-2 neon lamps (60 reqd.)

Resistors: 1/2 watt, 10% unless otherwise indicated

R1 through R11—68,000 ohms
 R12—10,000 ohms R13—See text
 R14—500 ohms, 2 watts
 R15—2,700 ohms, 2 watts
 R16—4,300 ohms, 1 watt
 R17—11,000 ohms, 5% R18—27,000 ohms
 R19 through R24—47,000 ohms
 R25 through R30—270,000 ohms
 R31 through R36—2,000 ohms
 R37, R38—10,000 ohm, 4-watt wirewound pot
 R39, R40, R41, R42—100,000 ohms
 S1 (power supply)—SPST toggle switch
 S1—DPDT pushbutton switch
 S2—1 pole, 6 position non-shorting rotary switch
 SR1 through SR12—Silicon rectifier; minimum ratings: 50 ma, 100 PIV (power supply, 400 PIV)
 T1—Power transformer, secondaries: 125 V @ 25 ma, 6.3 V @ 1 A
 TS1—8 lug barrier-type terminal strip
 V1 (power supply)—OC2 voltage-regulator tube

V1, V2, V3—12AU7A tube
 Misc.—10 x 8 x 8-in. sloping-panel cabinet, telephone dial, 7- and 9-pin tube sockets, 3 x 6 1/2 x 1 1/4-in. open-end chassis, 2 1/2 x 6-in. piece of perforated board, insulated tie posts (13 reqd.), flea clips

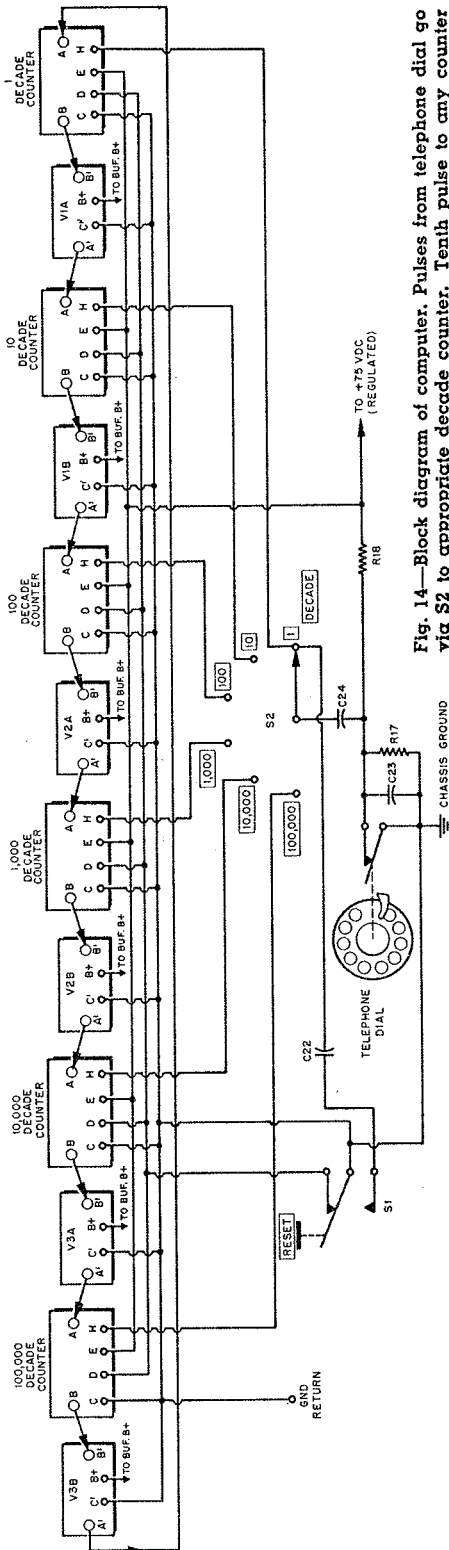

Fig. 14—Block diagram of computer. Pulses from telephone dial go via S2 to appropriate decade counter. Tenth pulse to any counter is fed via buffer amplifier (V1A-V3B) to the next higher decade.

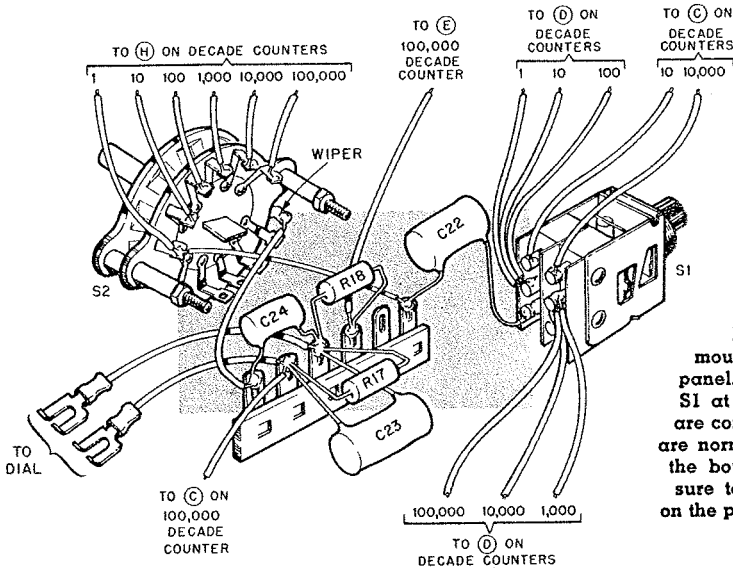

Fig. 15—Pictorial of parts mounted on bottom of the front panel. On reset push-button switch S1 at right, contacts at the bottom are common. Contacts in the middle are normally closed. The contacts at the bottom are normally open. Be sure to get the connections correct on the particular type switch you use.

The buffer amplifiers are built on a 6 x 3-in. piece of perforated board which is mounted in the cabinet on ½-in. brackets. The construction is conventional. Follow the layout in Figure 8.

Decade Counters

All decade counters (Fig. 10) are the same except for the value of resistor R13. They can be built on a 3 x 7-in. (or larger) piece of perforated board. All leads to connect the board to other parts of the computer should be about 20-in. long. The voltage to each decade counter must be individually established by selecting the value of resistor R13 (Figs. 10 and 11). Do not install the neon lamps or R13 yet.

Front Panel

Next thing to do is to mount the telephone dial (and its associated voltage-divider circuit C22, C23, C24, R17, R18), S1 and S2 on the front panel as shown in Fig. 16. Connect the circuit as shown in Fig. 15. Then connect the power (+75 VDC) and ground leads of this circuit to the power supply (see Fig. 14).

Determining R13's Value

After separating the neon lamps into six groups of ten lamps each, connect them to the decade-counters. The lamps for each decade counter should be selected with respect to firing voltage so as to fall within a close

range (about 3 V between highest and lowest) of each other.

Go back to the circuit just mounted on the front panel (Fig. 15). On any decade-counter board, temporarily connect a 500,000-ohm potentiometer in place of R13. Also, connect a lead from capacitor C24 to input-capacitor C1 on the decade counter. Connect the decade counter's ground return lead (C) and power supply lead (E) to the power supply, and connect a normally-closed push-button switch across the reset leads (C and D).

Turn on the power supply and check to see that the VR tube glows orange. If it doesn't, check the power supply for a wiring error. Set the potentiometer at maximum resistance (clockwise). You will probably find that more than one of the neon lamps lights. Turn the potentiometer counterclockwise until all the lamps go off.

Push reset switch S1 and see if the zero lamp lights. If it doesn't, increase slowly (turn clockwise) the potentiometer's resistance until the zero lamp *only* goes on when S1 is pushed. If after pushing switch S1 it is difficult to find a potentiometer setting where only the zero lamp stays on, replace the lamp or lamps that stay on with others from the same voltage group from which the decade counter's lamps were selected.

Chose lamps from the higher-voltage end of the group. If the zero lamp fails to fire as readily as the others on the board it is the offender. By carefully observing its be-

ELECTRONIC COMPUTER

havior for several settings of the potentiometer this can be determined. It may be helpful to choose the zero lamp from the lower-firing-voltage end of the group.

After you find the right potentiometer setting, turn the telephone dial and note if the proper number of pulses are counted. If you find that more than one lamp fires, or that some lamps don't light and resetting the potentiometer does not help, more lamps may have to be replaced.

If a lamp tends to not light consistently, it means that its firing voltage is too high, or its pulse-width requirement is too long for the group. The lamp should be replaced.

Careful observation of the lamps' behavior will tell you which lamps to replace. Above all don't become discouraged. Our experience was that after the initial selection, as many as 20 of the 60 lamps required replacement—almost four per decade counter. On the other hand, some boards worked properly right off.

Do not discard removed lamps. They may work perfectly on another board. Upon removal they can be rechecked for firing voltage and put back among your spares.

When a good set of lamps and a workable setting of potentiometer are obtained, measure the resistance of the potentiometer and substitute a resistor of the same value (more than one resistor may be required) in its place. A range of ± 10 percent should make little difference. Repeat this procedure for each decade counter.

Final Assembly

Do not use the schematics to connect the decade counters, power supply, buffer amplifiers, telephone dial, decade selector switch and reset switch. Instead, use the pictorials in Figs. 6, 8 and 15.

The reason for using the pictorials is that several connections often must be made for grounds, B+, etc., which don't appear in the schematic. Eliminating what you feel are apparently duplicate leads to save wire and time could result in erratic operation.

We used an 8 x 10 x 8-in. sloping-panel cabinet to house our computer. The photographs in Figs. 13 and 16 show the placement of all the major parts. The decade counter boards are held together with $\frac{3}{4}$ -in.-long spacers. The group of six boards is held

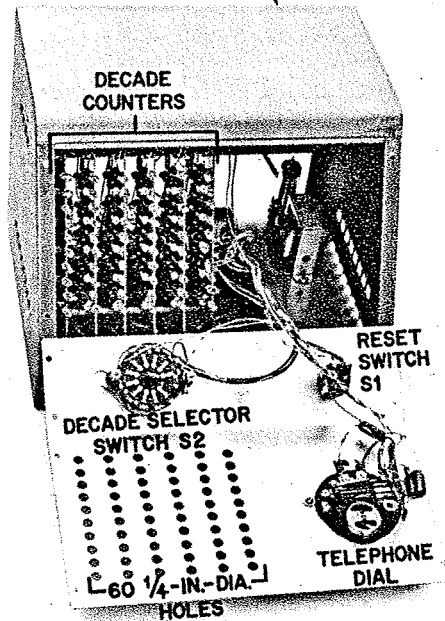

Fig. 16—View of computer before installation of front panel. Carefully position each of the neon lamps so they fit through holes in front panel.

to the cabinet with two 6-32 x $\frac{3}{4}$ -in. screws. Drill 60 $\frac{1}{4}$ -in. dia. holes in the front panel for the neon lamps. Also drill holes for the telephone dial, decade-selector switch S2 and reset-switch S1. All leads from these parts into the cabinet should be long to permit removal of the front panel and allow its placement at a convenient distance to permit testing and repair should it later be necessary.

Operation

After turning on power, let the computer warm up for about 10 minutes before using it.

● **Addition.** Perform the following steps to add these numbers:

$$\begin{array}{r} 26 \\ 9 \\ \hline 3081 \end{array}$$

- 1) Press reset-switch S1 and release it. All the zero lamps should come on and all other lamps should go off. If they don't press S1 again.
- 2) Set decade-selector switch S2 full clockwise—to the units position.

- 3) Dial 6, 9 and 1.
- 4) Turn S2 *one* position counterclockwise —to the tens position.
- 5) Dial 2, then 8.
- 6) Turn S2 *two* positions counterclockwise —to the thousands position.
- 7) Dial 3.

The answer should be 3116. Note that you *must not* dial the zero in 3081. Just skip over the hundreds decade when you reach the hundreds column. Matter of fact you *never* use the zero on the dial for any operation. Cover it over.

● **Subtraction.** While addition is performed by counting forward to higher numbers, subtraction is performed by counting backwards to lower numbers. Because the decade counters in the computer only count forward, we use the method known as *adding complements* to subtract.

Let's say you want to subtract 3 from 8. After pressing S1, set S2 to the units position and dial 8. Then dial a 6. Why 6? Because 6 is the nines complement of 3. The nines complement of a number is simply 9 minus the number!

Dialing a 6 will cause the units-decade counter to advance in six steps through 9, 0, 1, 2, 3, and stop at 4 and generate a carry pulse as it goes through zero. All we have to do is feed this carry pulse back into the units-decade counter and the number 5, the answer, will light. This process of adding back the carry pulse is called end-around carry.

The nines-complement numbers should be added to the telephone dial in red right next to the black numbers. Thus, the black number 1 will have a red 8 next to it, and the black 5 will have a red 4 next to it, and the black 9 will have a red 0 next to it, etc. (See our cover.)

When subtracting, dial the minuend (larger numbers) using the black numbers on the dial. Dial the subtrahend (smaller numbers) using the red numbers. When dialing a subtrahend like 000345, you *must* dial all the zeroes (using red numbers).

Reason for doing this is that when you subtract, you are really dialing-in complements. Therefore, since the complement of 0 is 9, all zeros must be dialed. However, a 9 is *not* dialed since its complement is 0. In other words, 0 is dialed in *red* and 9 is not.

Dialing in zeros gets that carry pulse from

one decade to the next higher decade, and so on, back to the units decade counter.

● **Multiplication.** To use the computer to multiply, you'll have to brush up on your multiplication tables and plan to do some mental arithmetic. (Paper and pencil are permitted.) Here's how you'd multiply:

$$\begin{array}{r} 3487 \\ \underline{123} \\ 10461 \\ 6974 \\ \underline{3487} \\ 428901 \end{array}$$

Set S2 to the units position and multiply 3×7 mentally. Dial a 1, the 1 of the answer 21.

Set S2 to the tens position and dial 2, the 2 of 21. Mentally multiply 3×8 and dial a 4, the 4 of the answer 24.

Set S2 to the hundreds position and dial the 2 of the former answer 24. Mentally multiply 3×4 and dial a 2, the 2 of the answer 12.

Turn S2 to the thousands position and dial a 1 of the former answer 12. Mentally multiply 3×3 and dial the answer, 9.

Now that we've finished with the 3 multiplier, repeat the entire procedure with the 2 multiplier. But be sure to start off with S2 in the *tens* position.

After finishing with the 2 multiplier, go on to the 1 multiplier and start with S2 in the *hundreds* position.

● **Division.** Like multiplication, division is going to rely on mental arithmetic. But the process is more complicated. We'll divide 428901 by 3487.

$$\begin{array}{r} 123 \text{ write down answer} \\ 3487 \overline{) 428901} \text{—dial in black} \\ \underline{-348700} \text{—dial in red} \\ 80201 \text{—red on glow lamps} \\ \underline{-69740} \text{—dial in red} \\ 10461 \text{—read on glow lamps} \\ \underline{-10461} \text{—dial in red} \\ 99999 \text{—read on glow lamps} \\ \text{(equivalent to zero remainder)} \end{array}$$

First, dial the dividend, 428901, using the black numbers and, of course, setting S2 to the appropriate position for each digit.

By observation, you can see that 3487 will go into 428910 at least 100 times. Mentally multiply 3487 by 100—you get 348700. Next, subtract 348700 (red numbers, and dial all zeros) from 428901. The remainder

[Continued on page 115]

Continued from page 54

construction as a matter of breadboards, left-over Band-Aid boxes and such other home-spun techniques as calling on the Almighty, but it wouldn't hurt to have a look at some of the real hardware of modern electronics. This book was intended to help technical-institute students toward the construction of prototypes but its material will be of interest to advanced hobbyists, too. Coverage ranges from chassis-punching to printed-circuit techniques and the material is well organized and presented.

YOUR TAPE RECORDER. By Joel Tall and Martin Clifford. Elpa Marketing Industries, New Hyde Park, N.Y. 32 pages. \$1

This slim volume, despite a pretty heavy orientation toward products marketed by the publisher, is a concise and valuable little handbook, particularly for those who would like to improve tape editing. It's available directly from the publisher.

And Make Note of . . .

NORTH AMERICAN RADIO-TV STATION GUIDE. By Vane A. Jones. Sams. 128 pages. \$1.95

INTRODUCTION TO ELECTRICAL CIRCUIT ANALYSIS. By Robert C. Carter. Holt, Rinehart & Winston. 500 pages. \$9.95

Electronic Computer

Continued from page 49

of this subtraction should be 080201 on the lamps.

Again, by observation we see that 3487 will go into 080201 at least 20 times. On paper multiply 3487 by 20—you get 69740. But since 69740 will be subtracted from 080210, a zero must be added to it at the left to make it a six digit number.

Now dial 010461 (dial all zeros). The result of this subtraction will be 999999 on the lamps. This means division is completed. In the complements of nine method of subtracting, this result is equivalent to 000000. If but smaller than the divisor, the division the remainder is other than zero (999999), should be carried further.

**color coded
nutdrivers**
now in new, handy kits

FOR BENCH, WALL OR TOOL BOX

Sturdy, new pebble-grain plastic cases provide handy means for keeping nutdrivers in good order on the workbench or in tool box for service calls. Lids snap shut, lock tight to protect tools. No. 77 case has hole in lid lock for wall hanging . . . molded compartments keep tools from tumbling out.

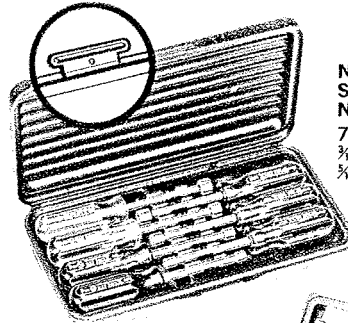

**No. 77
SOLID SHAFT
NUTDRIVER KIT**
7 Hex Openings:
3/16", 7/32", 1/4", 5/32",
5/16", 1/2", 3/8"

**No. HSC-18
HOLLOW SHAFT
NUTDRIVER KIT**

10 Hex Openings:
3/16", 7/32", 1/4", 5/32", 5/16",
1/2", 3/8", 7/16",
1/2", 3/8"

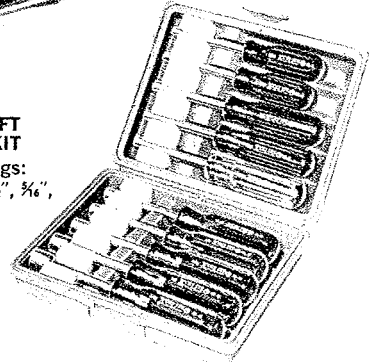

PROFESSIONAL QUALITY

Precision fit, case-hardened sockets; polished and plated steel shafts; shockproof, breakproof, color coded plastic (UL) handles.



XCELITE INC. • 16 BANK ST., ORCHARD PARK, N. Y.

Send Catalog 162 with information on 77 and HS6-18 sets.

name _____

address _____

city _____ state & zone _____

In Canada contact Charles W. Pointon, Ltd.