

Panasonic

ideas for life

Phototriac Coupler for the Industrial Machinery, Consumer Electronics, and SSR Markets

Phototriac Coupler (APT)

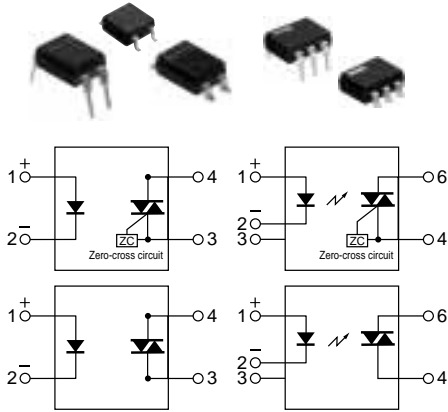

FEATURES

- Two types available: Non zero-cross type and zero-cross type
- Many package sizes available.
- High dielectric strength. (Between input and output: SOP 3, 750 V; DIP 5,000 V)
- This type is for both 100 and 200 V AC.
- Terminal 5 of the DIP 6-pin type is completely molded.

TYPICAL APPLICATIONS

- Industrial equipment such as NC machines, chip moulder, robots and so on
- AC fan-motor control
- Control of heated-water motor and flush valve for personal hygiene system
- Heater control for copiers and other products
- Triac driver for SSRs

TYPES

1. SOP Type

Type	Output rating*		Type	Package size	Part No.		Packing quantity in tape and reel
	Repetitive peak OFF-state voltage	ON-state RMS current			Picked from the 1/2-pin side	Picked from the 3/4-pin side	
AC type	600 V	50 mA	Zero-cross	SOP4pin	APT1211SX	APT1211SZ	1,000 pcs.
			Non zero-cross		APT1221SX	APT1221SZ	

Notes: (1) Tape package is the standard packing style. Also available in tube. (Part No. suf x "X" or "Z" is not needed when ordering; Tube: 100 pcs.; Case: 2,000 pcs.)

(2) For space reasons, the initial letters of the product number "APT" and "S" are omitted on the product seal.

The package type indicator "X" and "Z" are omitted from the seal. (Ex. the label for product number APT1221SZ is 1221.)

* Repetitive peak OFF-state voltage and surge on current express the peak AC.

2. DIP Type

Type	Output rating*		Type	Package size	Part No.				Packing quantity	
	Repetitive peak OFF-state voltage	ON-state RMS current			Through hole terminal	Surface-mount terminal		Tube	Tape and reel	
						Tube packing style	Tape and reel packing style			
AC type	600 V	100 mA	Zero-cross	DIP4pin	APT1211	APT1211A	APT1211AX (Picked from the 1/2-pin side)	APT1211AZ (Picked from the 1/2/3-pin side)	[DIP4pin] 1 tube contains 100 pcs. 1 batch contains 1,000 pcs. [DIP6pin] 1 tube contains 50 pcs. 1 batch contains 500 pcs.	[DIP4pin] [DIP6pin] 1,000 pcs.
			Non zero-cross		APT1221	APT1221A	APT1221AX (Picked from the 1/2-pin side)	APT1221AZ (Picked from the 1/2/3-pin side)		
			Zero-cross	DIP6pin	APT1212	APT1212A	APT1212AX (Picked from the 1/2/3-pin side)	APT1212AZ (Picked from the 4/6-pin side)		
			Non zero-cross		APT1222	APT1222A	APT1222AX (Picked from the 1/2/3-pin side)	APT1222AZ (Picked from the 4/6-pin side)		

Note: For space reasons the initial letters "APT" of the product number for the DIP 4-pin type, the letter "A", which indicates the SMD terminal shape for the DIP 4-pin and 6-pin types, and the package type indications "X" and "Z" have been omitted from the product label. (Example: The label for product number APT1221AZ is 1221.)

* Repetitive peak OFF-state voltage and surge on current express the peak AC.

Phototriac Coupler (APT)

RATING

1. Absolute maximum ratings (Ambient temperature: 25°C 77°F)

Item		Symbol	APT1211S	APT1221S	APT1211(A)	APT1221(A)	APT1212(A)	APT1222(A)	Remarks
Input	LED forward current	I_F	50 mA						
	LED reverse voltage	V_R	6 V						
	Peak forward current	I_{FP}	1 A						f = 100 Hz, Duty Ratio = 0.1%
Output	Repetitive peak OFF-state voltage	V_{DRM}	600 V						
	ON-state RMS current*	$I_{T(RMS)}$	0.05 A			0.1 A			AC
	Non-repetitive surge current	I_{TSM}	0.6 A			1.2 A			In one cycle at 60Hz
Total power dissipation		P_T	350 mW			500 mW			
I/O isolation voltage		V_{iso}	3,750 V AC			5,000 V AC			
Temperature limits	Operating	T_{opr}	-40°C to +100°C -40°F to +212°F						Non-condensing at low temperatures
	Storage	T_{stg}	-40°C to +125°C -40°F to +257°F						

* Do not exceed 50 mA of ON state RMS current in case of following load voltage condition.
APT1211, APT1221: more than 100 V AC; APT1212, APT1222: more than 120 V AC

2. Electrical characteristics (Ambient temperature: 25°C 77°F)

Item			Symbol	APT1211S, APT1211(A), APT1212(A)	APT1221S, APT1221(A), APT1222(A)	Condition
Input	LED dropout voltage	Typical	V_F	1.18 V		$I_F = 10 \text{ mA}$
		Maximum		1.3 V		
	LED reverse current	Typical	I_R	—		$V_R = 6 \text{ V}$
		Maximum		10 μA		
Output	Peak OFF-state current	Typical	I_{DRM}	—		$I_F = 0$ $V_{DRM} = 600 \text{ V}$
		Maximum		1 μA		
	Peak On-state voltage	Typical	V_{TM}	1.3 V		$I_F = 10 \text{ mA}$ $I_{TM} = 0.05 \text{ A}$
		Maximum		2.5 V		
	Holding current	Typical	I_H	0.3 mA		
		Maximum		3.5 mA		
Critical rate of rise of OFF-state voltage	Minimum	dv/dt	500 V/ μs		$V_{DRM} = 600 \text{ V} \times 1/\sqrt{2}$	
Transfer characteristics	Trigger LED current*	Maximum	I_{FT}	10 mA		$V_D = 6 \text{ V}$ $R_L = 100 \Omega$
	Zero-cross voltage**	Maximum	V_{ZC}	50 V	—	$I_F = 10 \text{ mA}$
	Turn on time***	Maximum	T_{ON}	100 μs		$I_F = 20 \text{ mA}$ $V_D = 6 \text{ V}$ $R_L = 100 \Omega$
	I/O capacitance	Maximum	C_{iso}	1.5 pF		f = 1 MHz $V_B = 0$
	I/O resistance	Minimum	R_{iso}	50 G Ω		500 V DC

*Recommended LED current $I_F = 20 \text{ mA}$

**Applicable part numbers: APT1211S, APT1211, APT1212.

***Turn on time

Note: For type of connection, see Page 35.

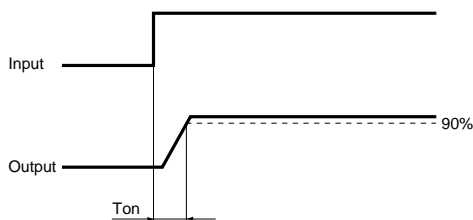

DIMENSIONS

mm inch

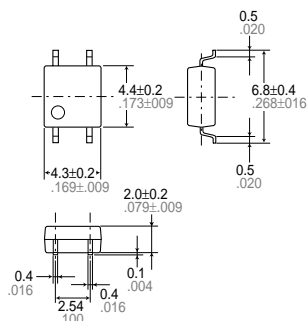

Terminal thickness = 0.15 ±0.006

General tolerance: ±0.1 ±0.004

Recommended mounting pad (TOP VIEW)

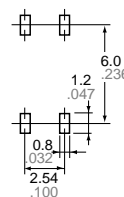

Tolerance: ±0.1 ±0.004

Phototriac Coupler (APT)

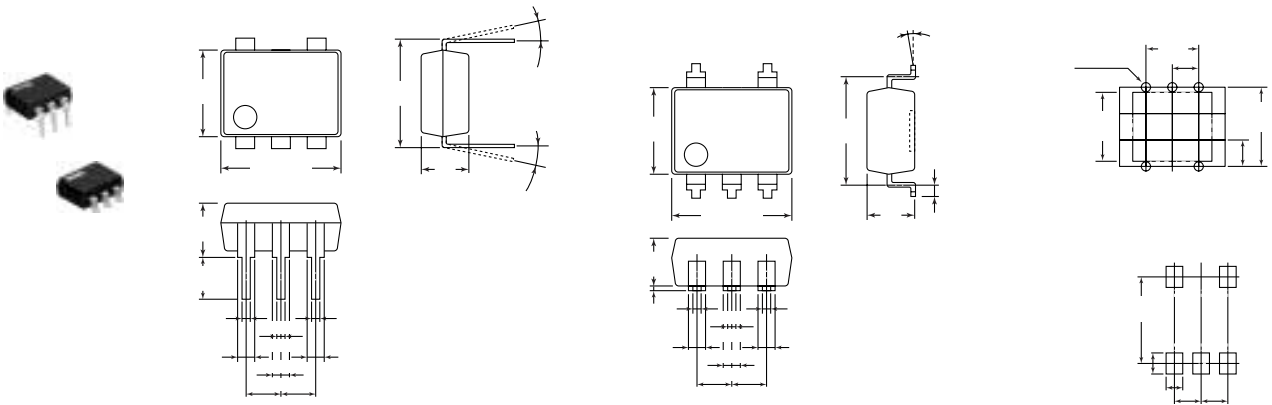
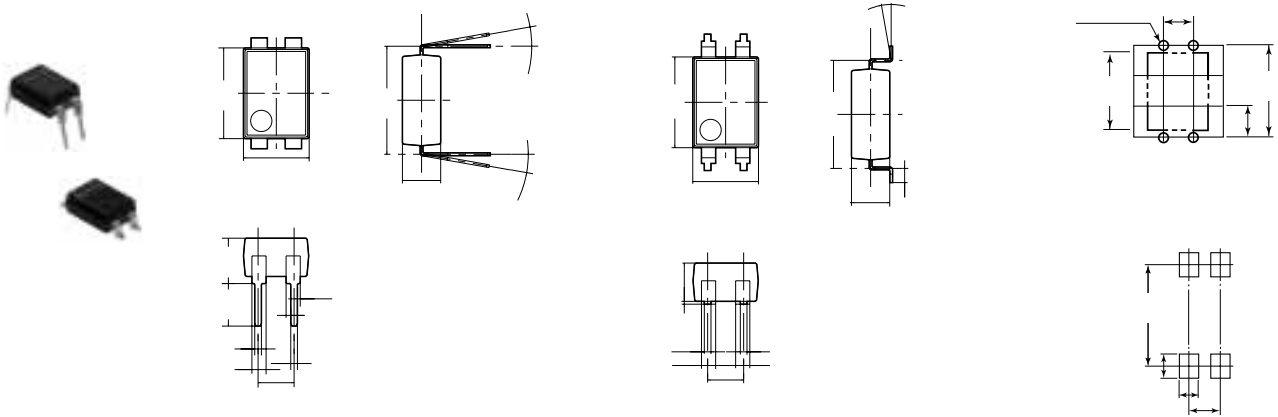

SCHEMATIC AND WIRING DIAGRAMS

Notes: E: Power source at input side; I_F: Trigger LED forward current; V_L: Load voltage; I_L: Load current;

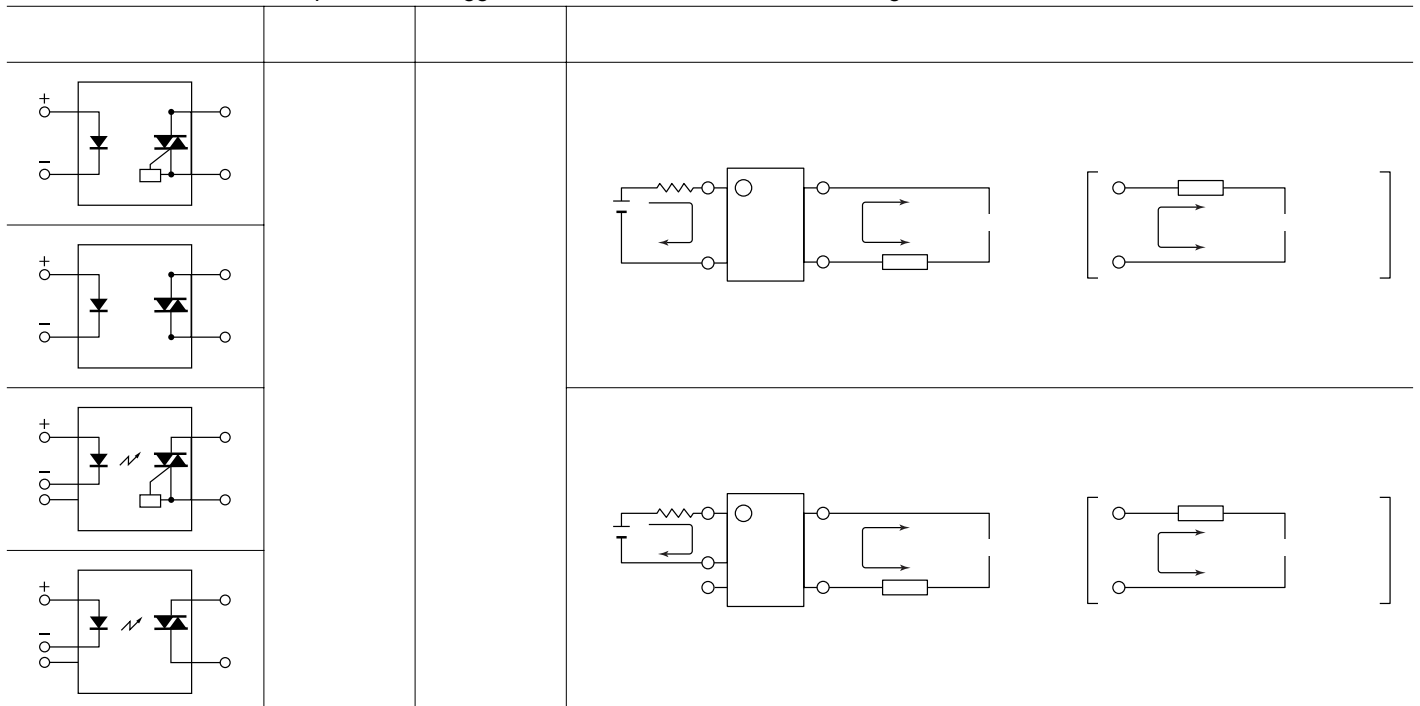

Phototriac Coupler (APT)

REFERENCE DATA

1. Effective on current vs. ambient temperature characteristics

Allowable ambient temperature: -40°C to $+100^{\circ}\text{C}$
 -40°F to $+212^{\circ}\text{F}$

Tested sample: APT1211S, APT1221S

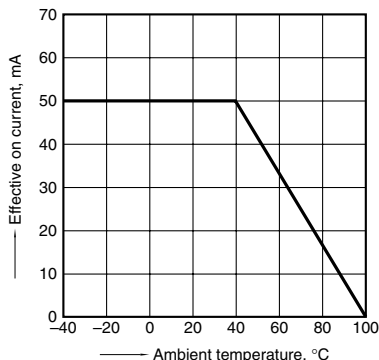

2. Effective on current vs. ambient temperature characteristics

Allowable ambient temperature: -40°C to $+100^{\circ}\text{C}$
 -40°F to $+212^{\circ}\text{F}$

Tested sample: APT1211, APT1221

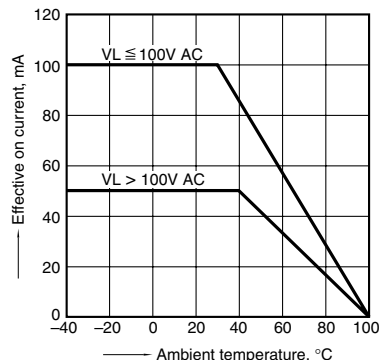

3. Effective on current vs. ambient temperature characteristics

Allowable ambient temperature: -40°C to $+100^{\circ}\text{C}$
 -40°F to $+212^{\circ}\text{F}$

Tested sample: APT1212, APT1222

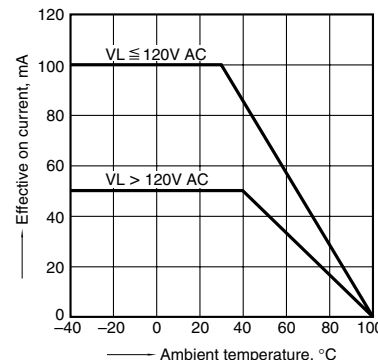

4. On voltage vs. ambient temperature characteristics

Trigger LED current: 10 mA; ON current: 50 mA (AC)

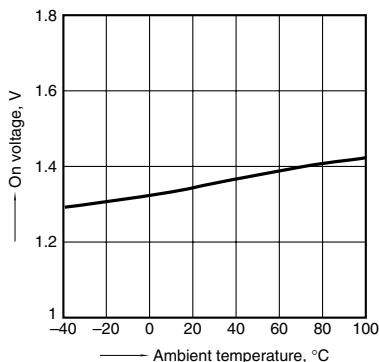

5. Trigger LED current vs. ambient temperature characteristics

Load voltage: 6 V (DC); Load resistance: 100Ω

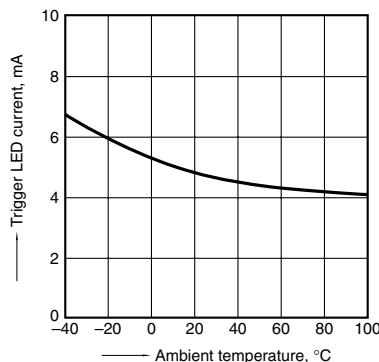

6. LED dropout voltage vs. ambient temperature characteristics

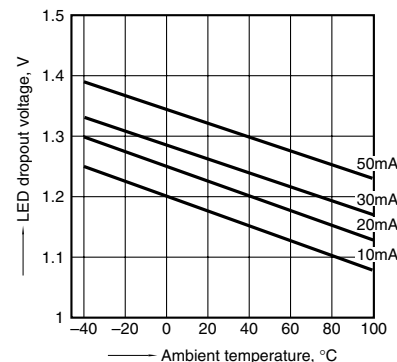

7. Turn on time vs. trigger LED current

Load voltage: 6 V (DC)
Load resistance: 100Ω

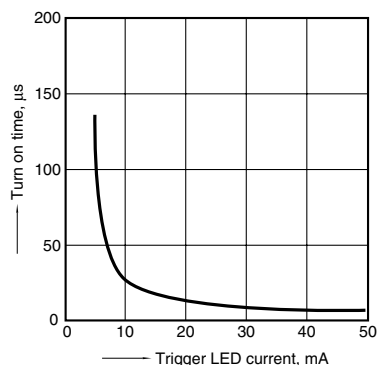

8. Off state leakage current vs. load voltage

Ambient temperature: 25°C 77°F

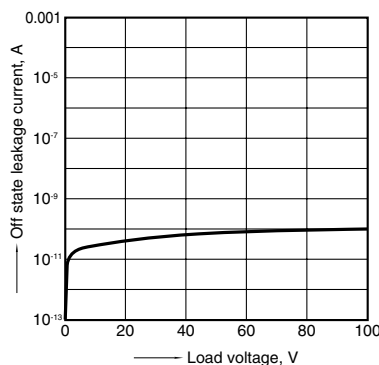

9. Hold current vs. ambient temperature characteristics

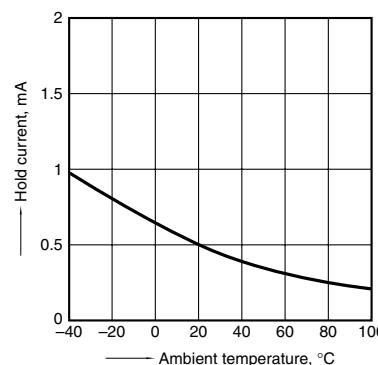

10. Zero-cross voltage vs. ambient temperature characteristics

Trigger LED current: 10 mA (APT1211S)

