

NOTES: UNLESS OTHERWISE SPECIFIED

REVISIONS			
REV	DESCRIPTION	DATE	APPROVED

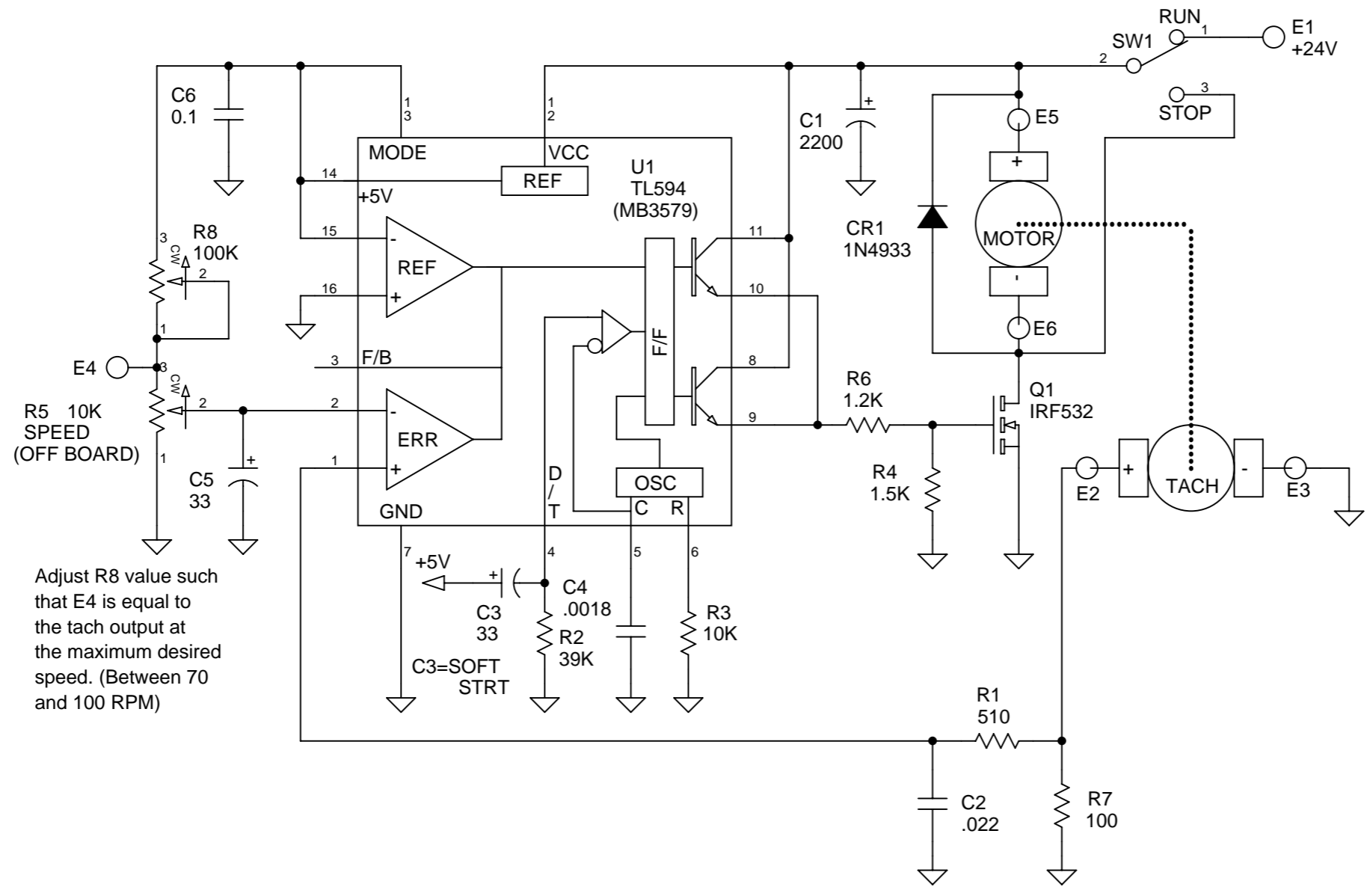

Adjust R8 value such that E4 is equal to the tach output at the maximum desired speed. (Between 70 and 100 RPM)

**CAD GENERATED DRAWING, DO NOT MANUALLY CHANGE**

ITEM NO.	QTY REQD	CAGE CODE	PART OR IDENTIFYING NO.	DESCRIPTION	MATERIAL SPECIFICATION
<b>PARTS LIST</b>					
UNLESS OTHERWISE SPECIFIED DIMENSIONS ARE IN INCHES TOLERANCES ARE: FRACTIONS    DECIMALS    ANGLES ±                .XX ±0.3    0.3° ±			CONTACT NO.		
INTERPRET DRAWING PER DOD-STD-100 INTERPRET DIMENSIONS AND TOLERANCES PER ANSI Y14.5M-1982 REMOVE ALL BURRS AND SHARP EDGES .03R MAX ABBREVIATIONS PER MIL-STD-12 SURFACE ROUGHNESS ✓ HOLED TOLERANCES PER AND10387			APPROVALS      DATE		TITLE
NEXT ASSY      USED ON			DRAWN		
APPLICATION UNLESS OTHERWISE SPECIFIED IN CONTRACT, APPLICATION DATA IS ONLY FOR			CHECKED		SIZE    FSCM NO.      DWG. NO.      REV.
DO NOT SCALE DRAWING			ENGINEER		
DO NOT SCALE DRAWING			PROJ ENGR		SCALE
DO NOT SCALE DRAWING			APPROVED		
DO NOT SCALE DRAWING			QA		1 OF